

*Detail of balcony joint*

*Detal połączenia balkonu  
skala 1:10*

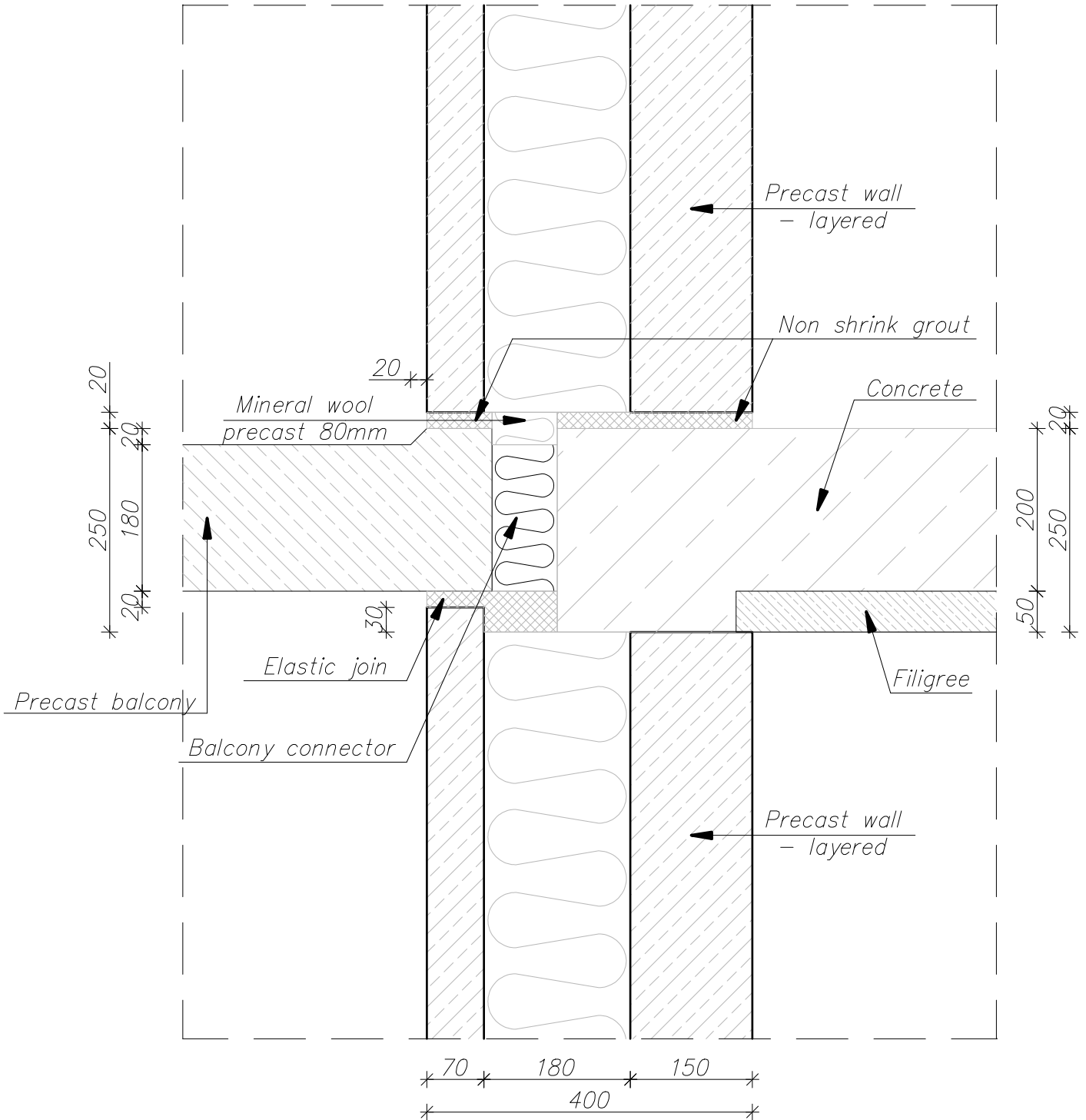

# Detail of balcony joint

Detal połączenia balkonu  
skala 1:10



HM FACTORY Sp. z o.o.

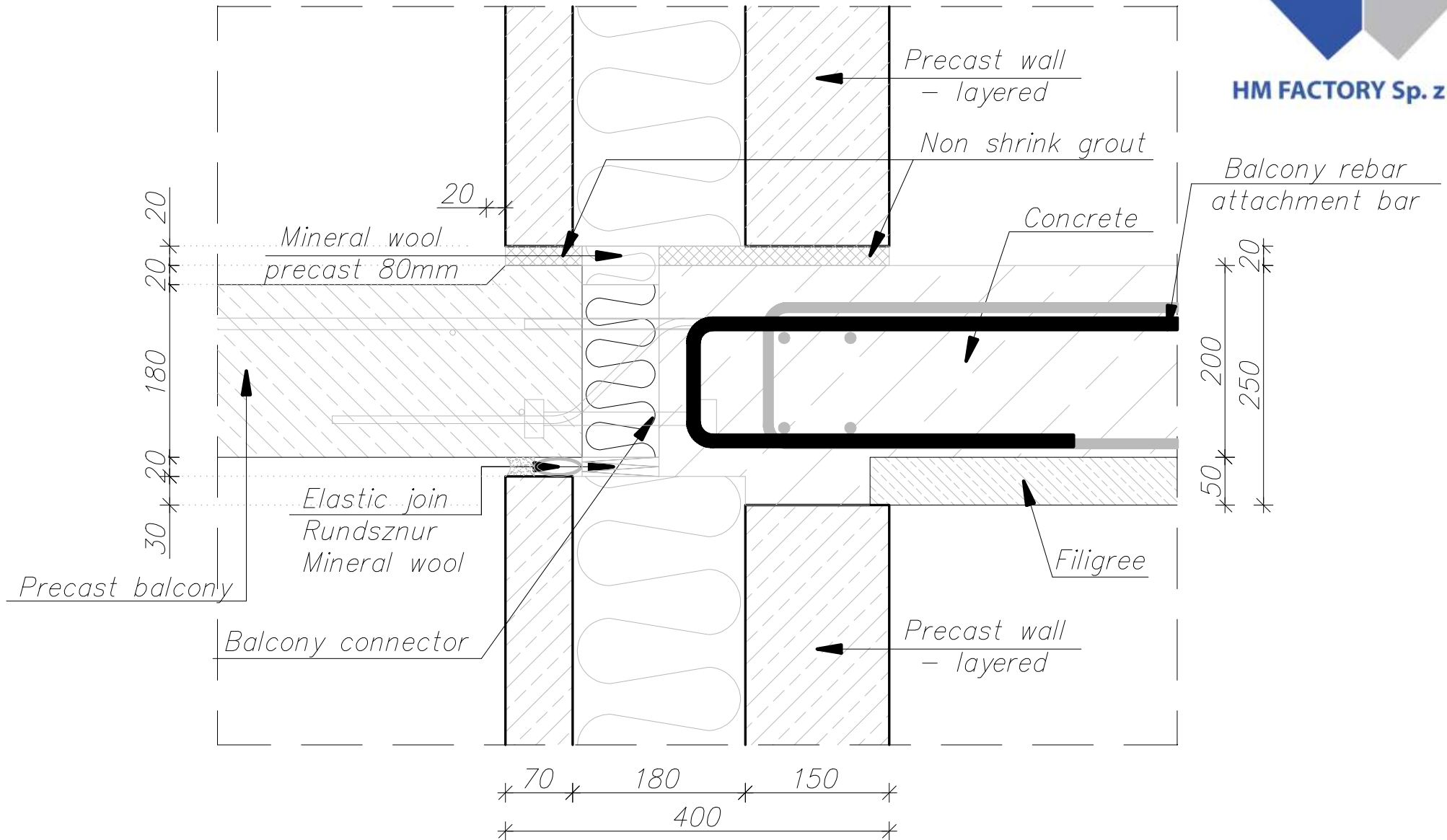

# The detail of the window joint (vertical)

Szczegół połączenia okiennego (pionowe)  
skala 1:10

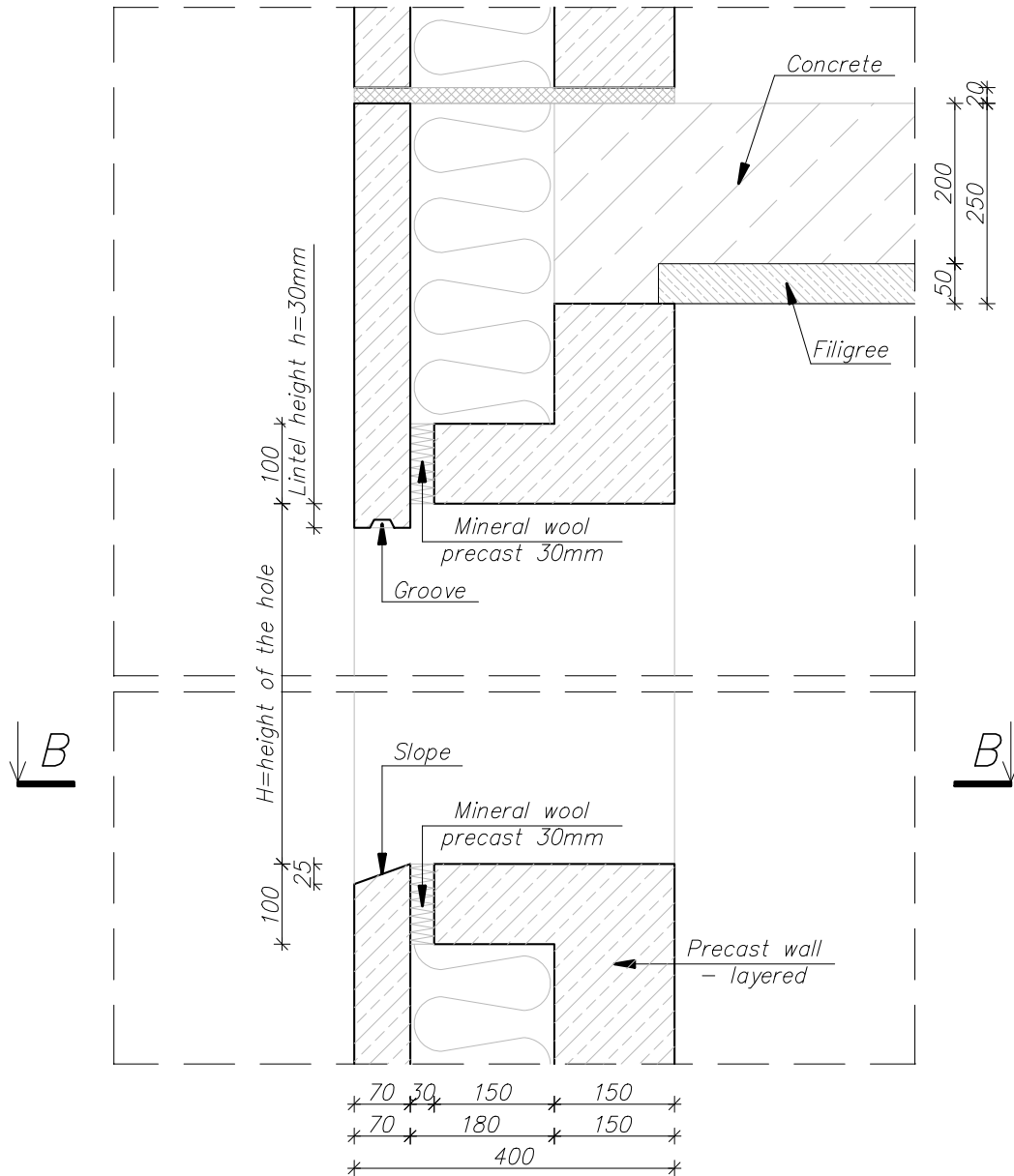

## Section B-B

Przekrój B-B  
skala 1:10

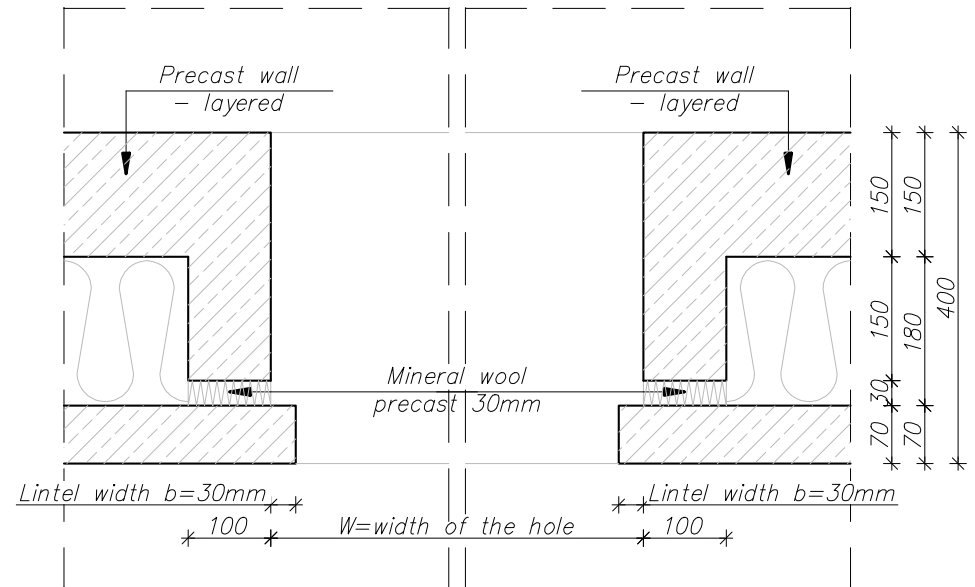

HM FACTORY Sp. z o.o.

# Detail of connecting balconies (D1)

Detal łączenia balkonów  
skala 1:10

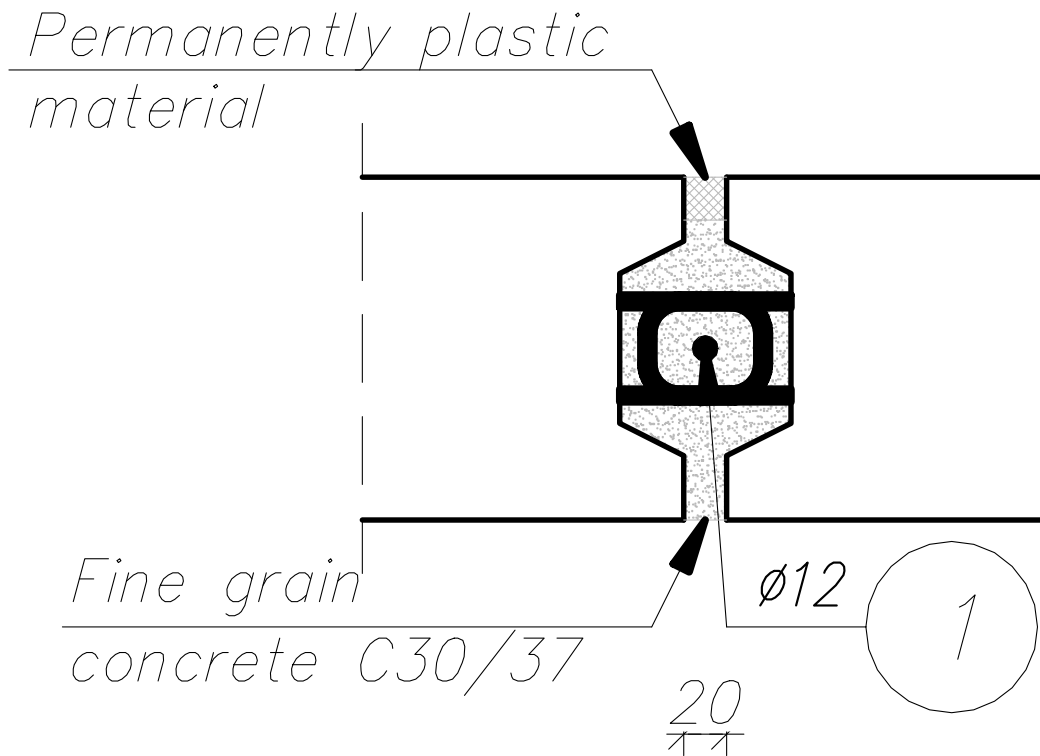

1)  $4\varnothing 12 - L = 1300$



HM FACTORY Sp. z o.o.

# Detail of the support of the stairs (DOWN)

detal oparcia schodów (DOLNE)

skala 1:10 / scale 1:10

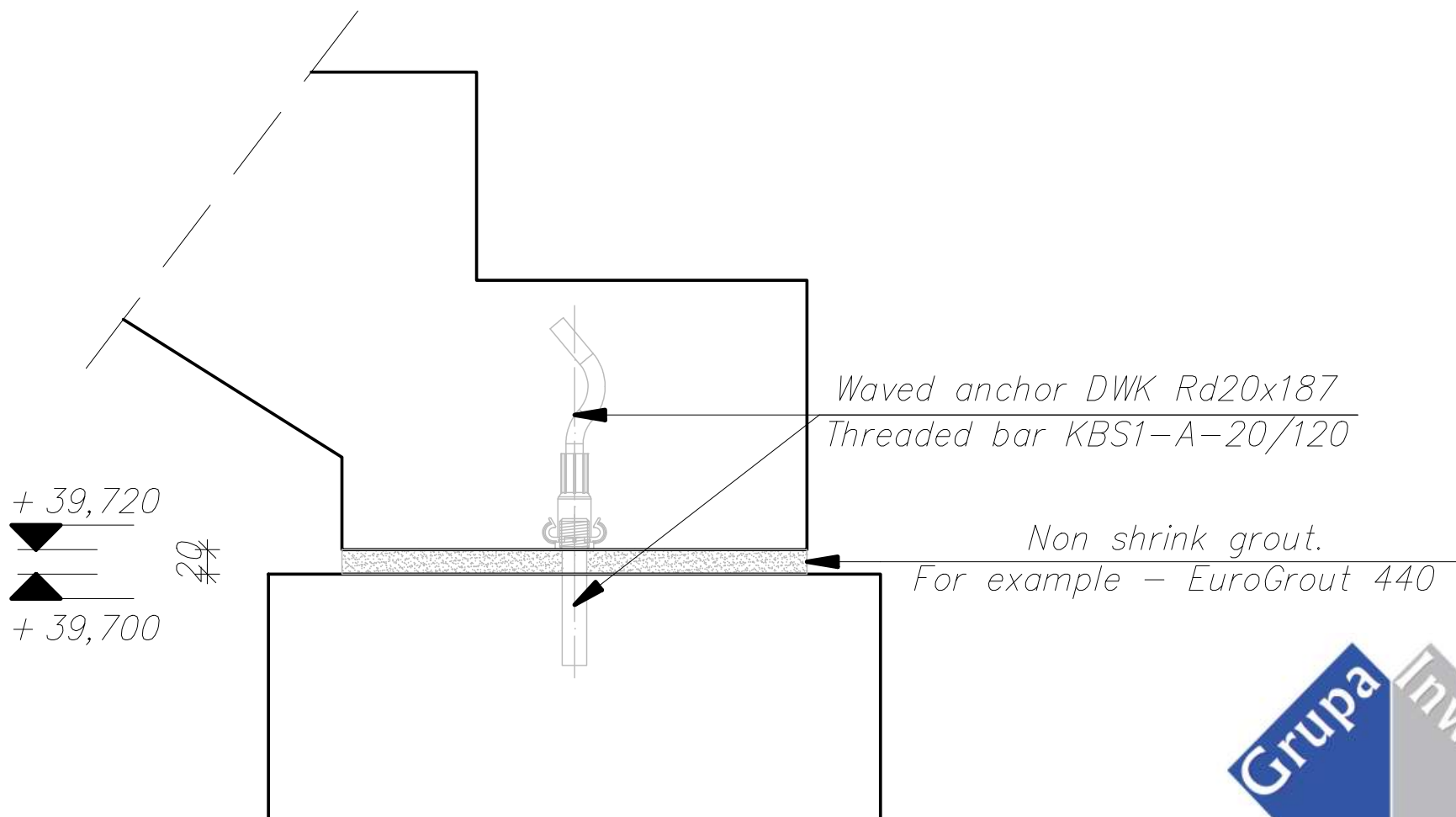

HM FACTORY Sp. z o.o.

# Detail of the support of the stairs (TOP)

detal oparcia schodów (GÓRNY)

skala 1:10 / scale 1:10

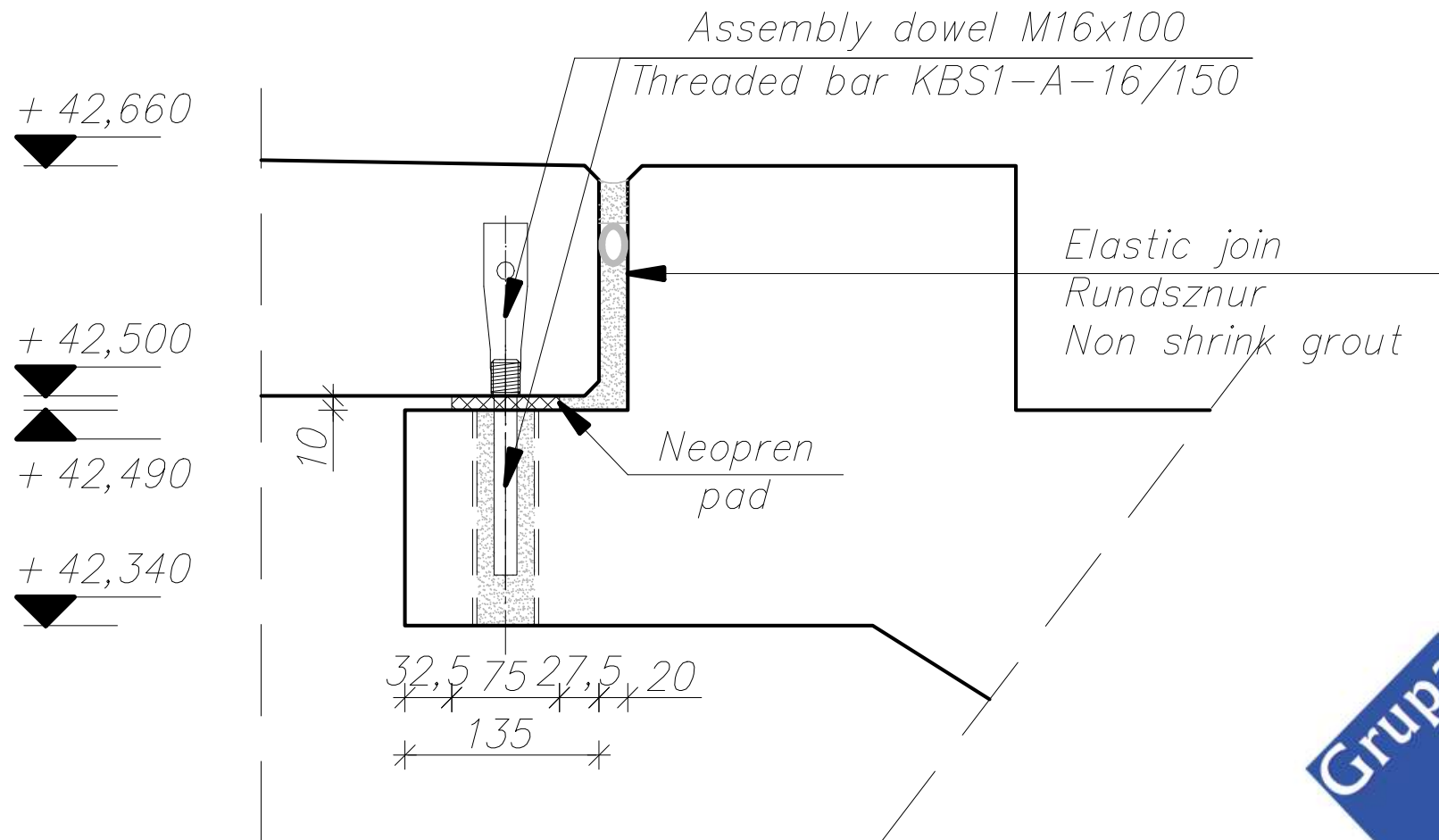

HM FACTORY Sp. z o.o.

010

012

013

014

015

016

017

Detail of wall connections – type 7 (top)

Detal łączenia ścian – typ 7  
skala 1:10

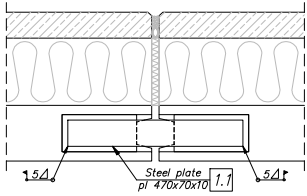

Detail of wall connections – type 8 (top)

Detal łączenia ścian – typ 8  
skala 1:10

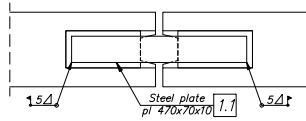

Detail of wall connections – type 10 (top)

Detal łączenia ścian – typ 10  
skala 1:10

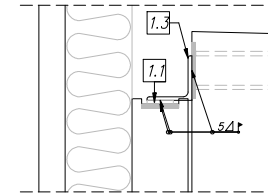
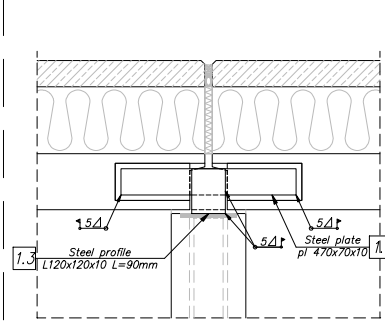

Detail of wall connections – type 9 (top)

Detal łączenia ścian – typ 9  
skala 1:10

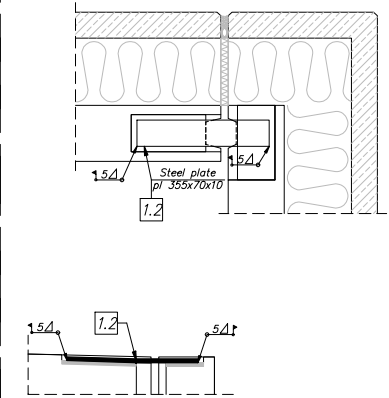

Detail of wall connections – type 11 (top)

Detal łączenia ścian – typ 11  
skala 1:10

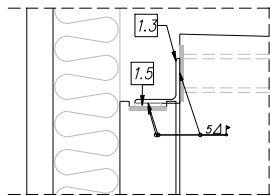
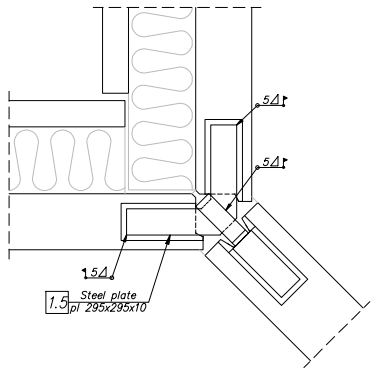

Detail of wall connections – type 12 (top)

Detal łączenia ścian – typ 12  
skala 1:10

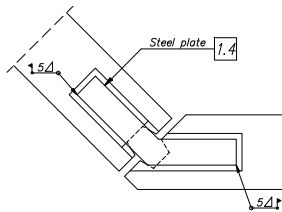

HM FACTORY Sp. z o.o.

# Detail of joint to the foundation – type 1

Detal połączenia z fundamentem – typ 1  
skala 1:10

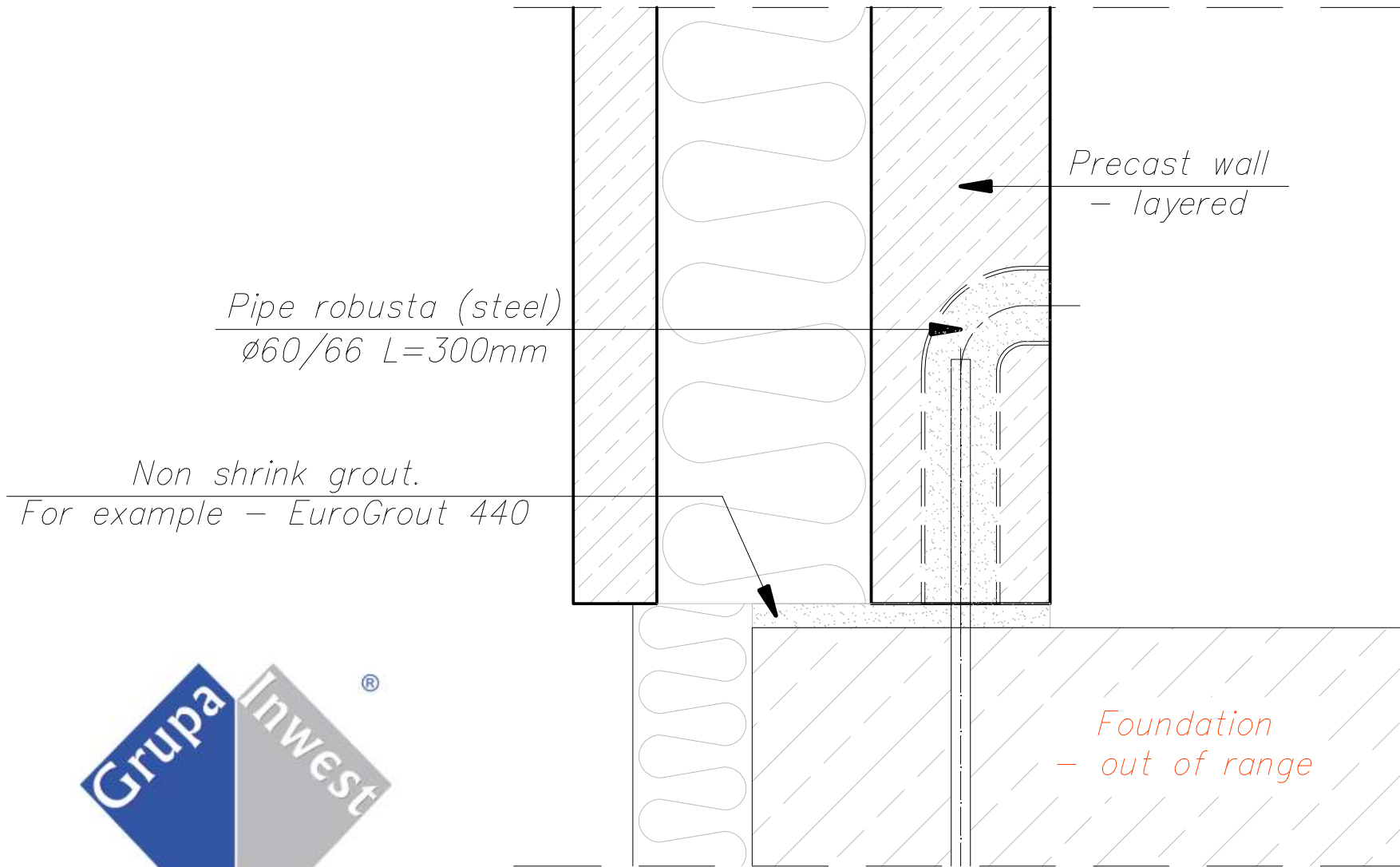

HM FACTORY Sp. z o.o.



# Detail of interior wall connection (vertical)

Detal połączenia ścian wew. (pionowe)  
skala 1:10

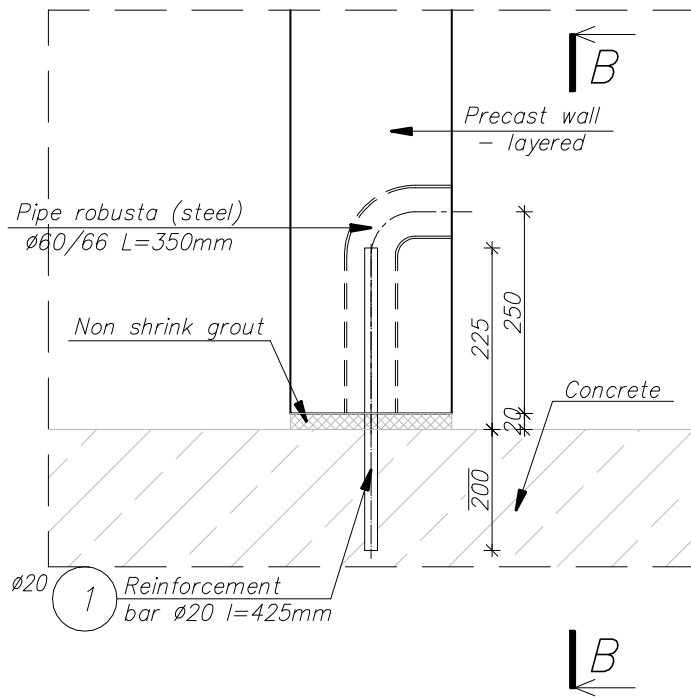

## Section B-B

Przekrój B-B  
skala 1:10

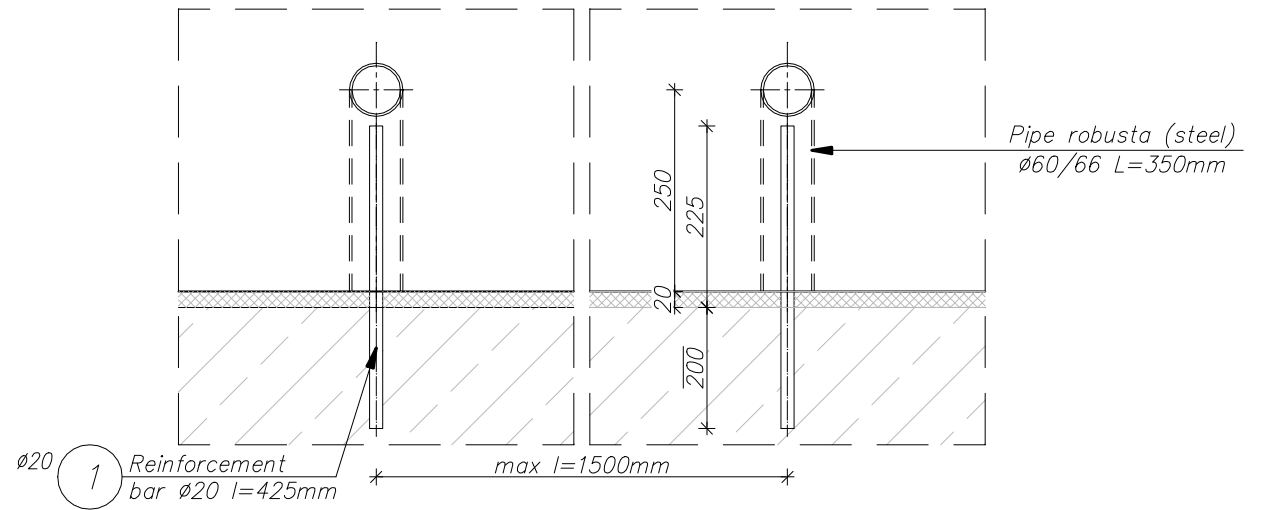

HM FACTORY Sp. z o.o.

# Detail of joint to the foundation – type 2

Detal połączenia z fundamentem – typ 2  
skala 1:10

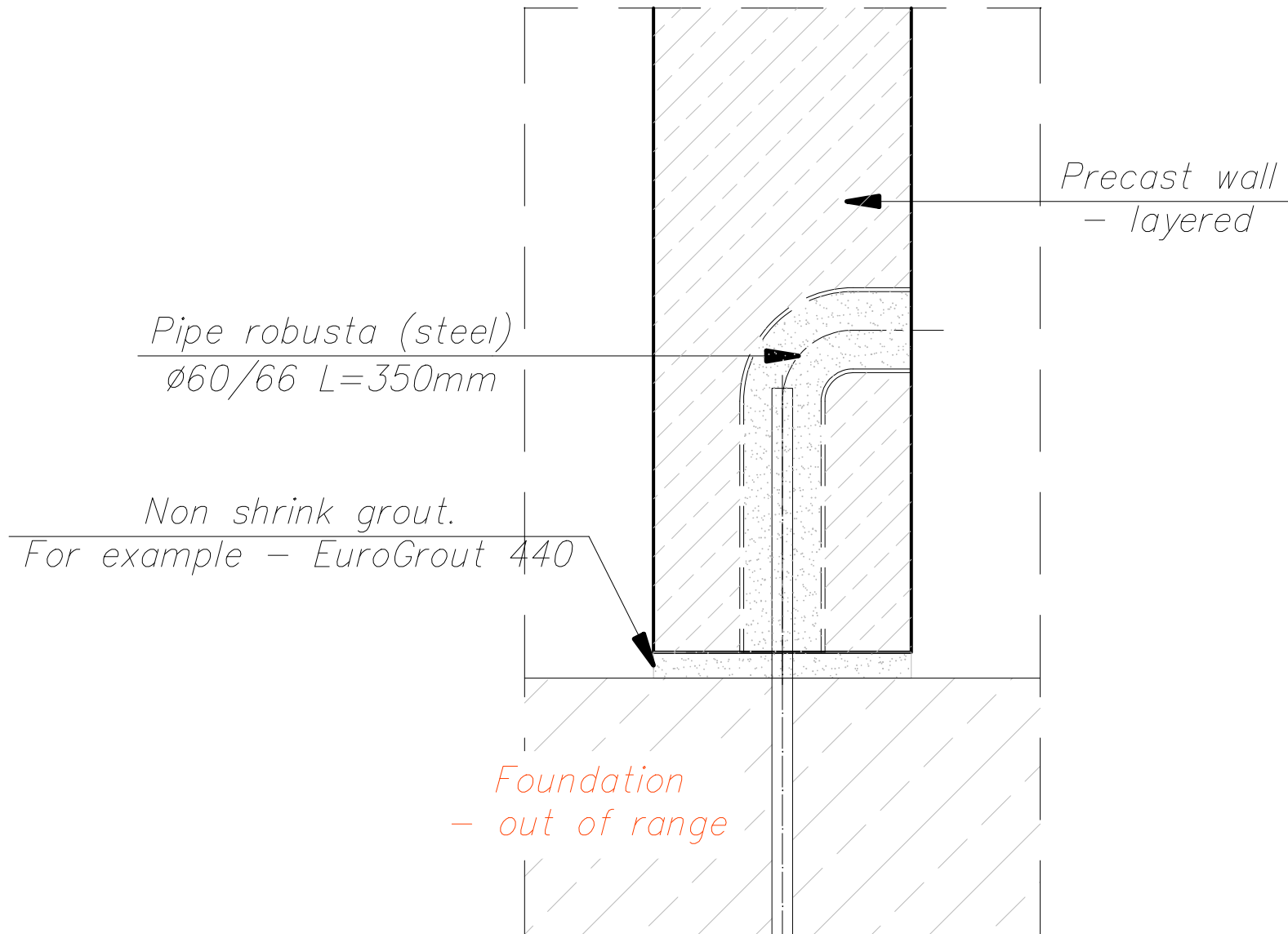

HM FACTORY Sp. z o.o.

# Detail of wall connections – type 6

Detal łączenia ścian – typ 6  
skala 1:10

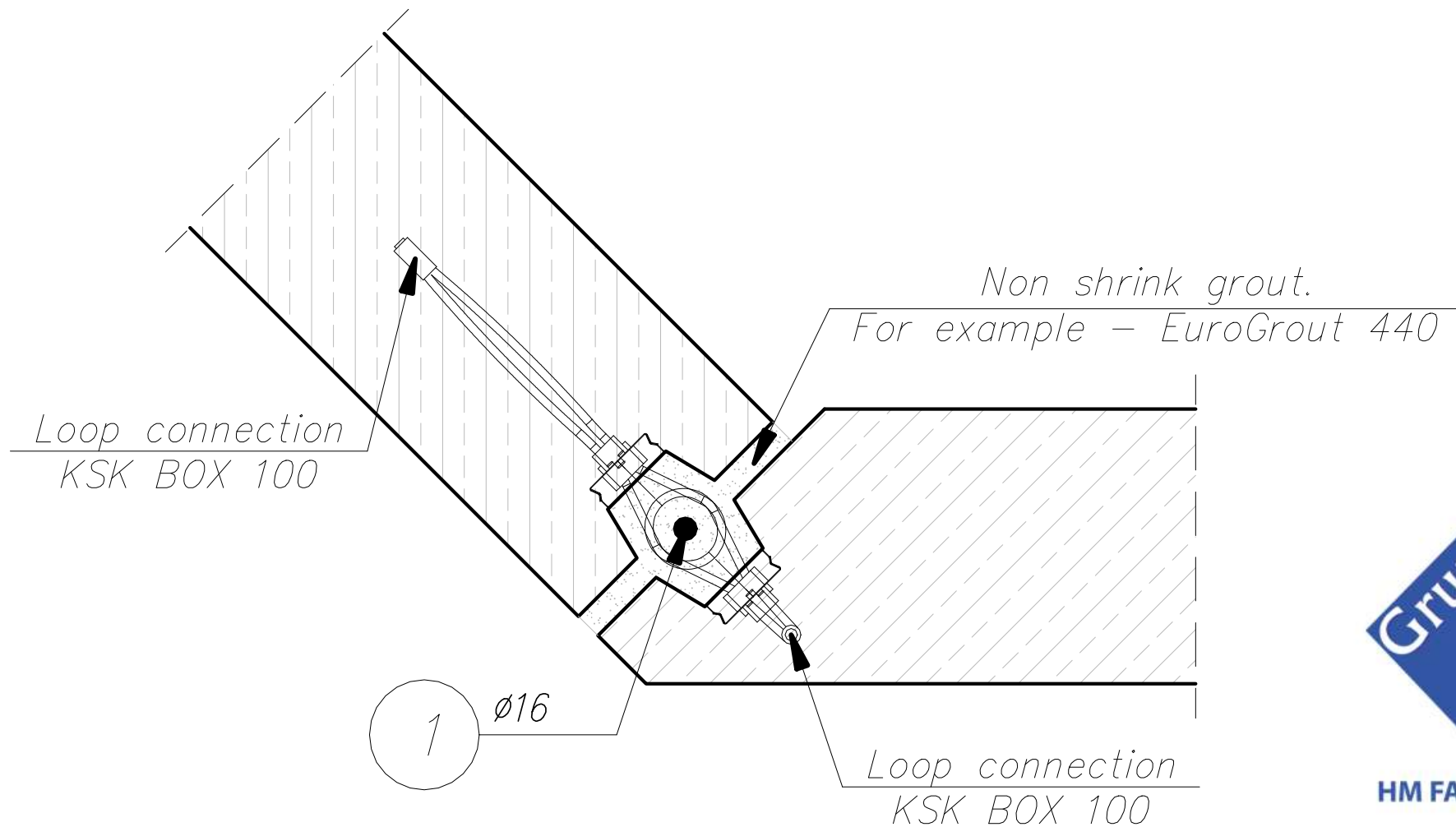

# Detail of wall joint (vertical)

Detal połączenia ścian (pionowe)  
skala 1:10

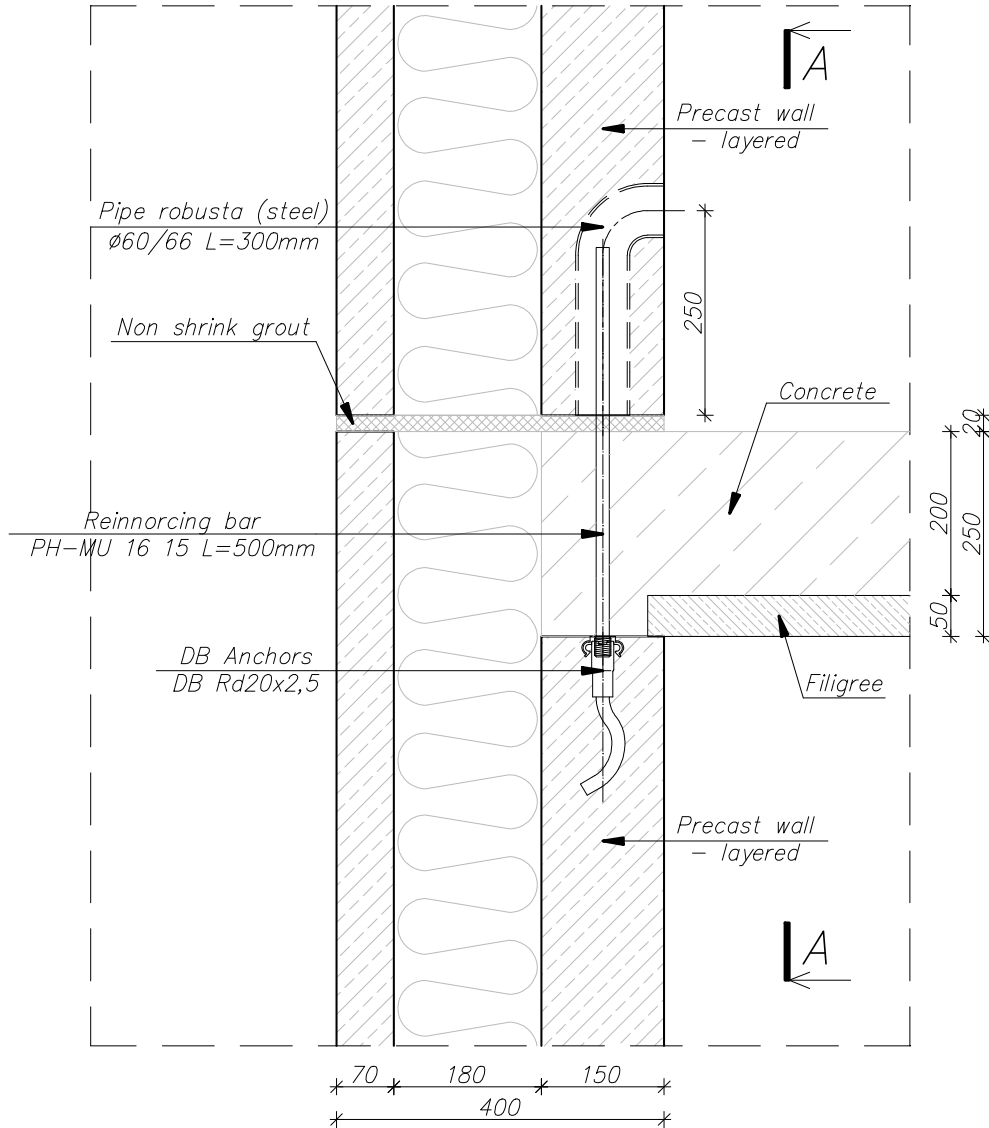

# Section A-A

Przekrój A-A  
skala 1:10

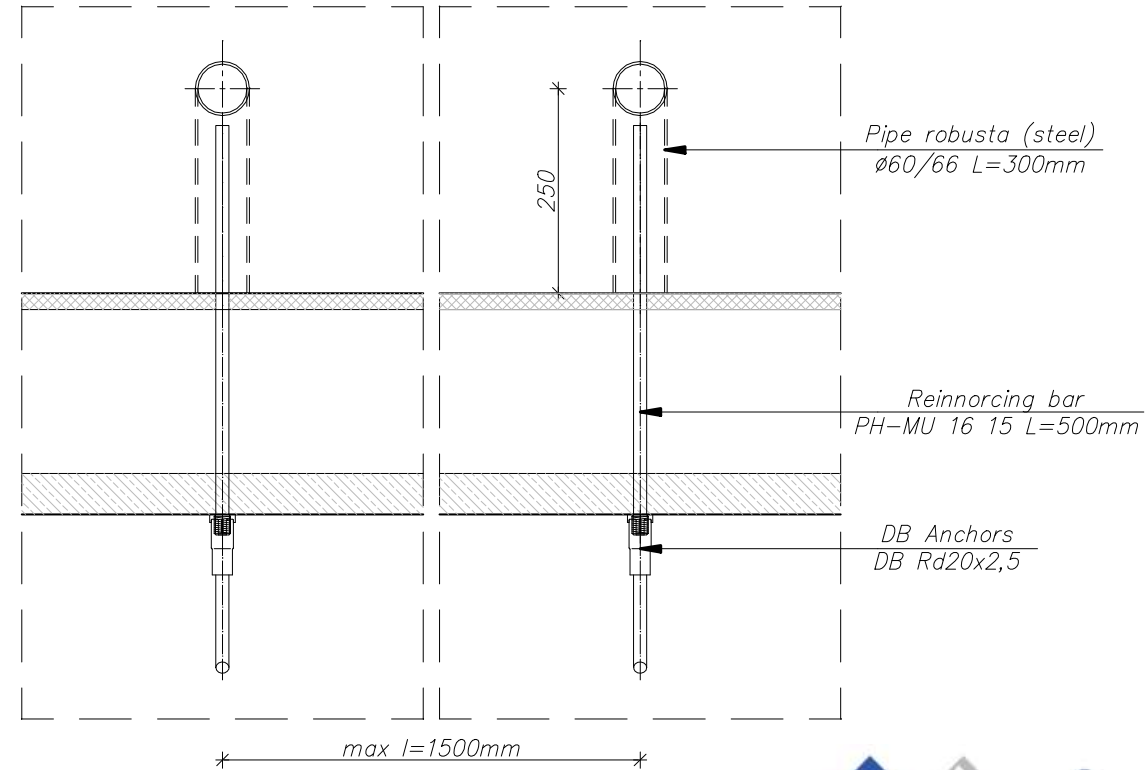

HM FACTORY Sp. z o.o.

# Detail of wall connections – type 5

Detal łączenia ścian – typ 5  
skala 1:10

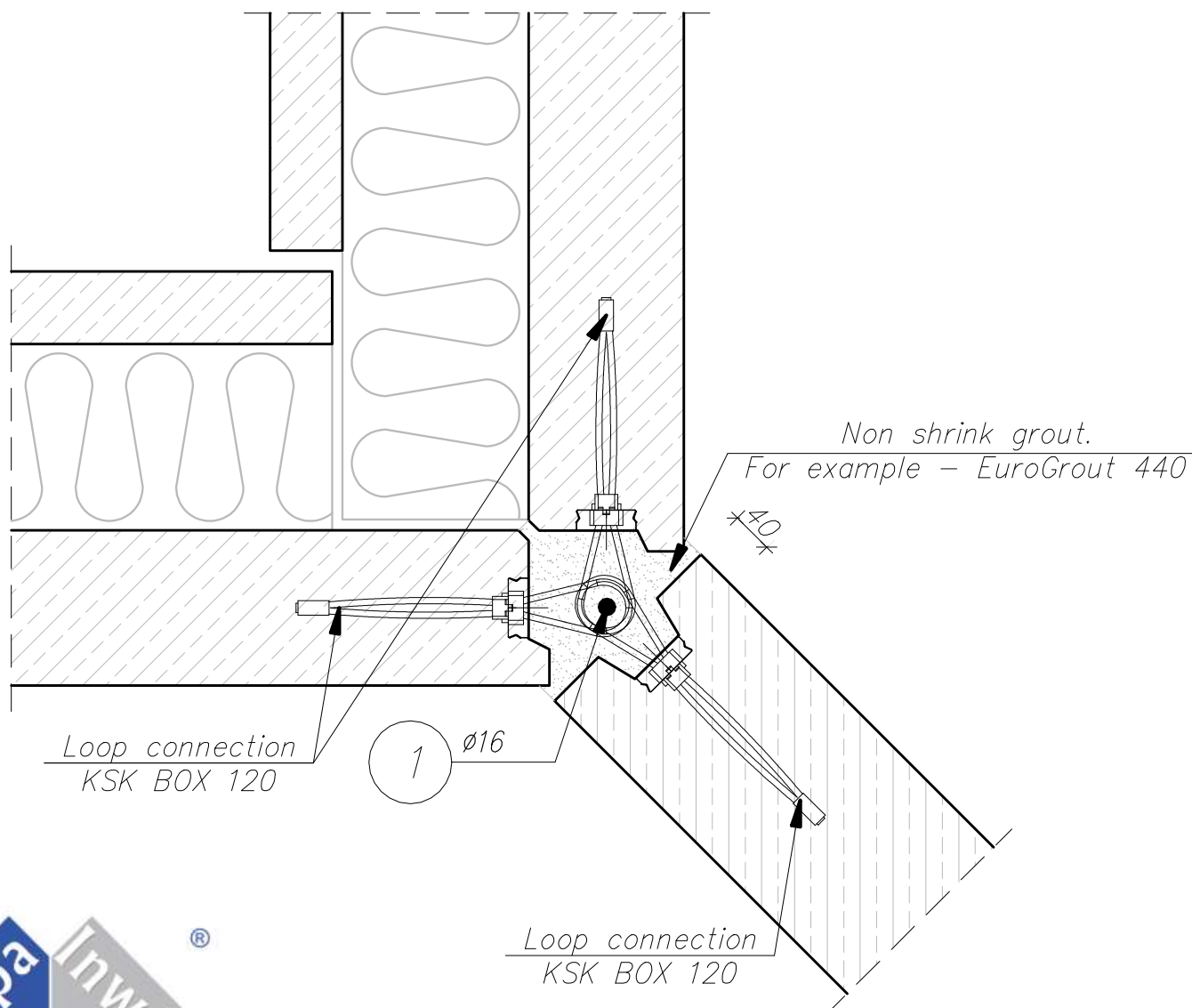

HM FACTORY Sp. z o.o.

# Detail of wall connections – type 3

Detal łączenia ścian – typ 3  
skala 1:10



HM FACTORY Sp. z o.o.

Elastic joint  
Rundsznur  
Mineral wool

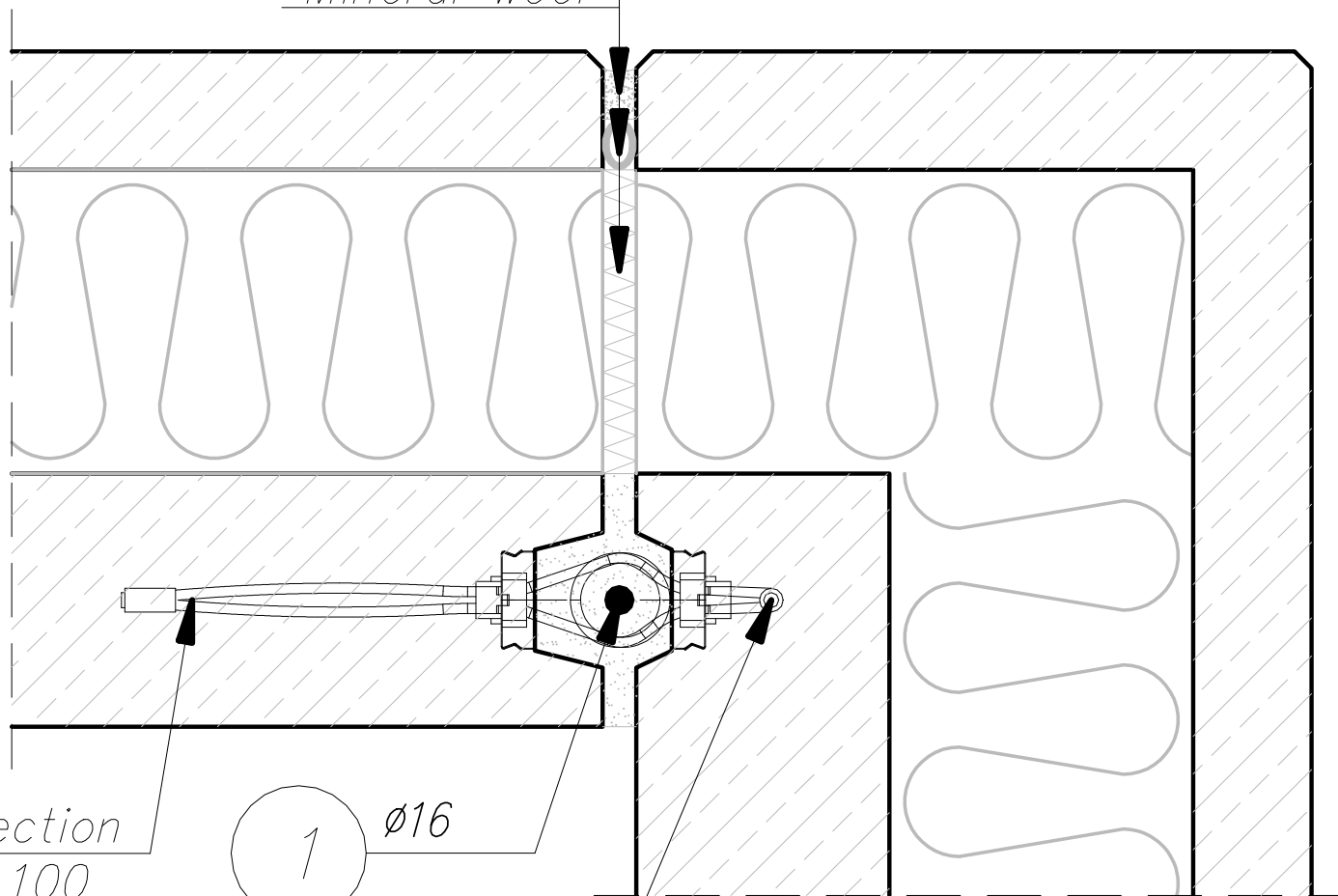

Loop connection  
KSK BOX 100

1 Ø16

Loop connection  
KSK BOX 80

# Detail of wall joint (horizontal)

Detal połączenia ścian (poziome)  
skala 1:25



HM FACTORY Sp. z o.o.

1 15 $\phi$ 16-L=2990

1  $\phi$ 16

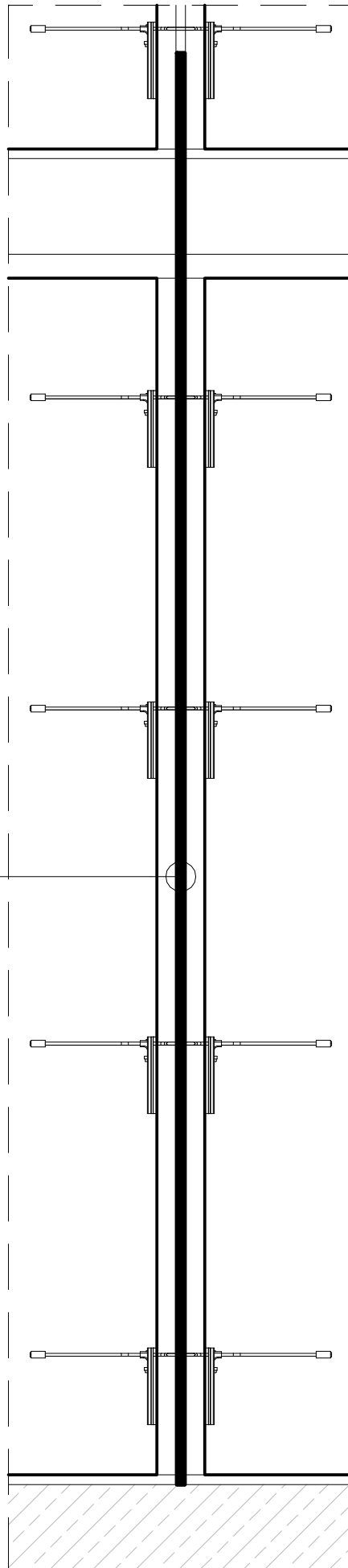

105,160 \*  
270 \*  
235 \*  
160 \*  
490 \*  
160 \*  
540 \*  
160 \*  
490 \*  
105,160 \*  
20 \*  
Wall height L=2500

Loop connection

- KSK BOX 80
- KSK BOX 100
- KSK BOX 120
- KSK BOX 140

# Detail of wall connections – type 1

Detal łączenia ścian – typ 1  
skala 1:10

Elastic joint

Rundsznur

Mineral wool

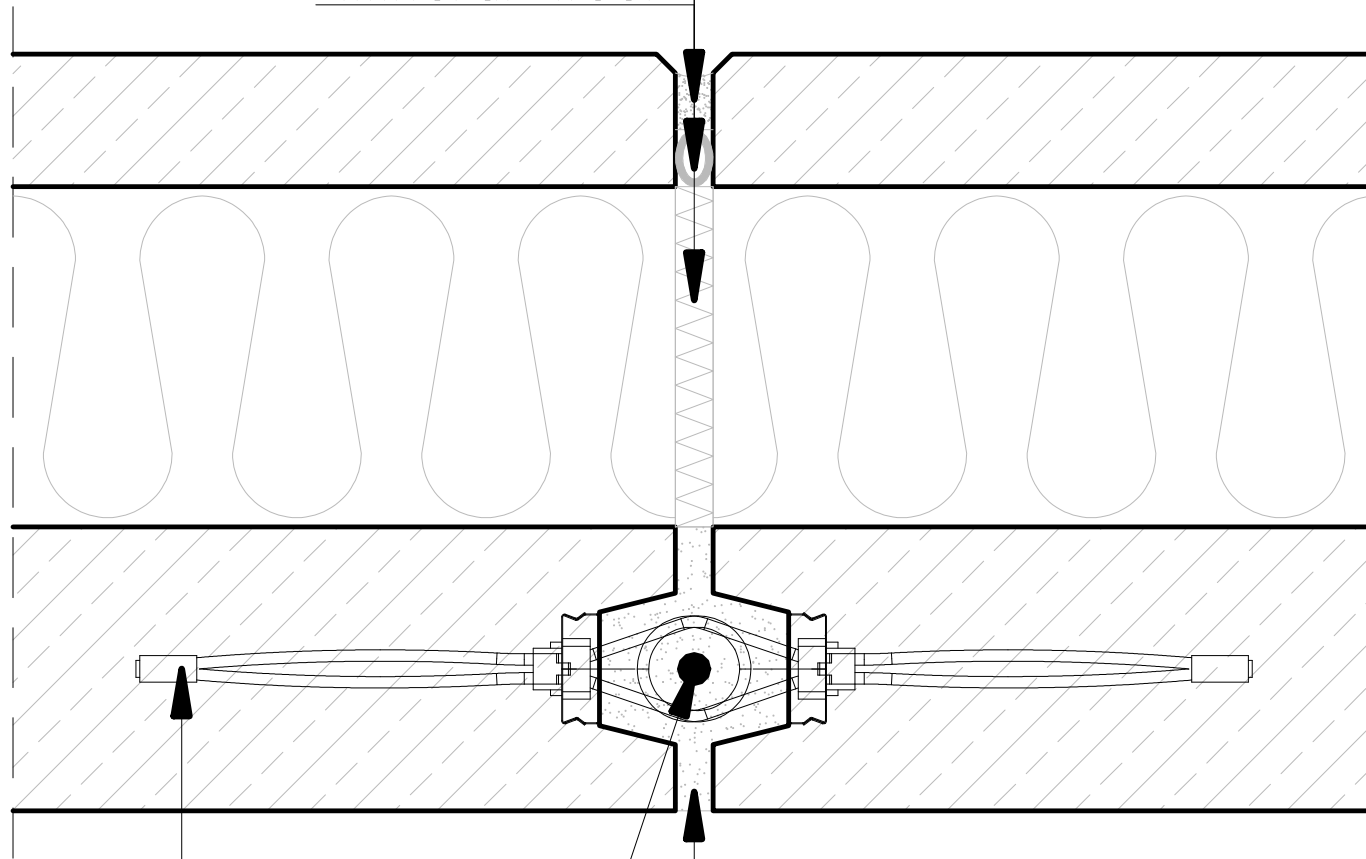

Loop connection  
KSK BOX 100

1 Ø16

Non shrink grout.

For example – EuroGrout 440



HM FACTORY Sp. z o.o.



# Detail of wall connections – type 2

Detal łączenia ścian – typ 2  
skala 1:10

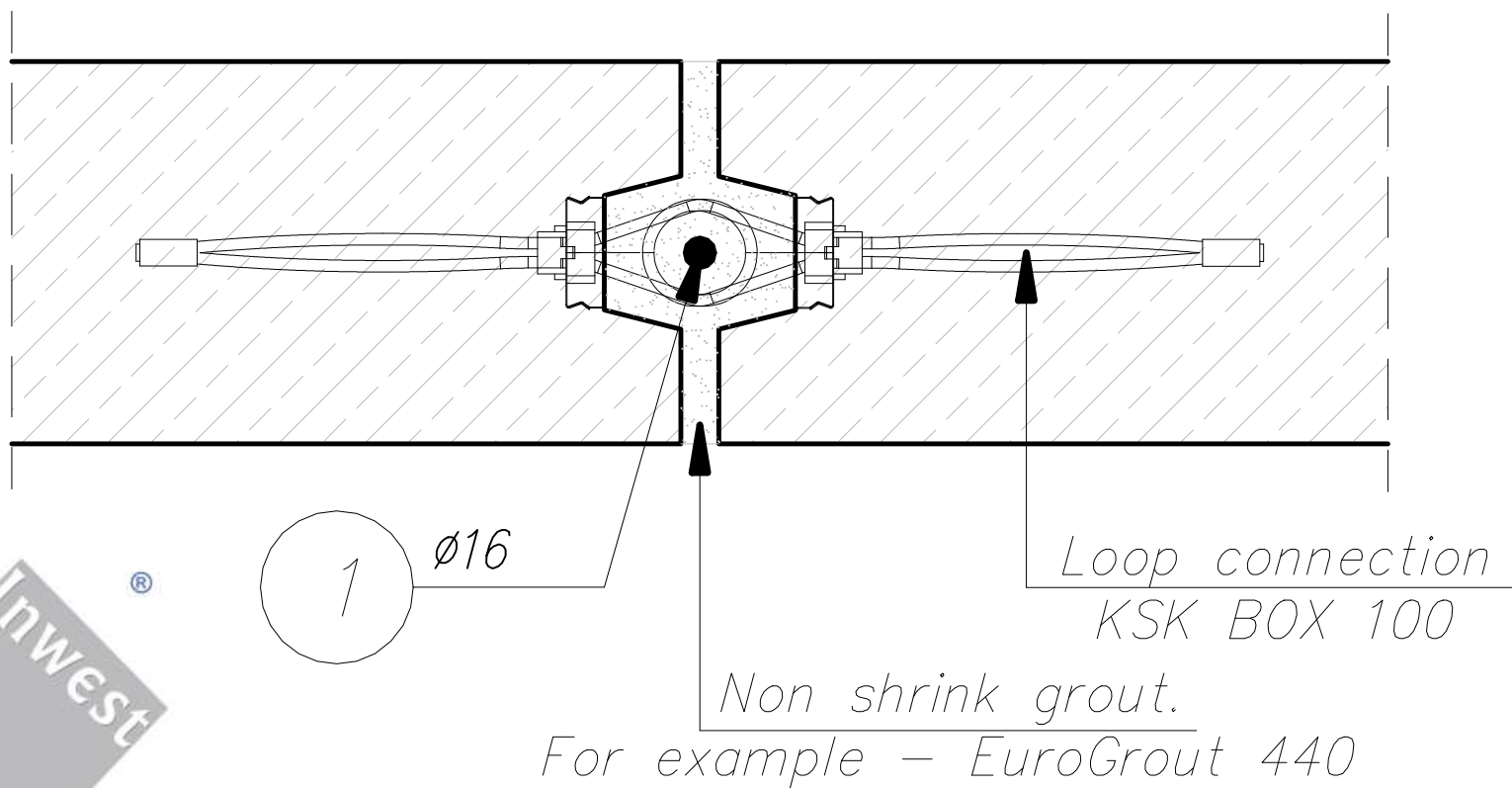

HM FACTORY Sp. z o.o.

# Detail of external wall connection (vertical)

Detal połączenia ścian zew. (pionowe)  
skala 1:10

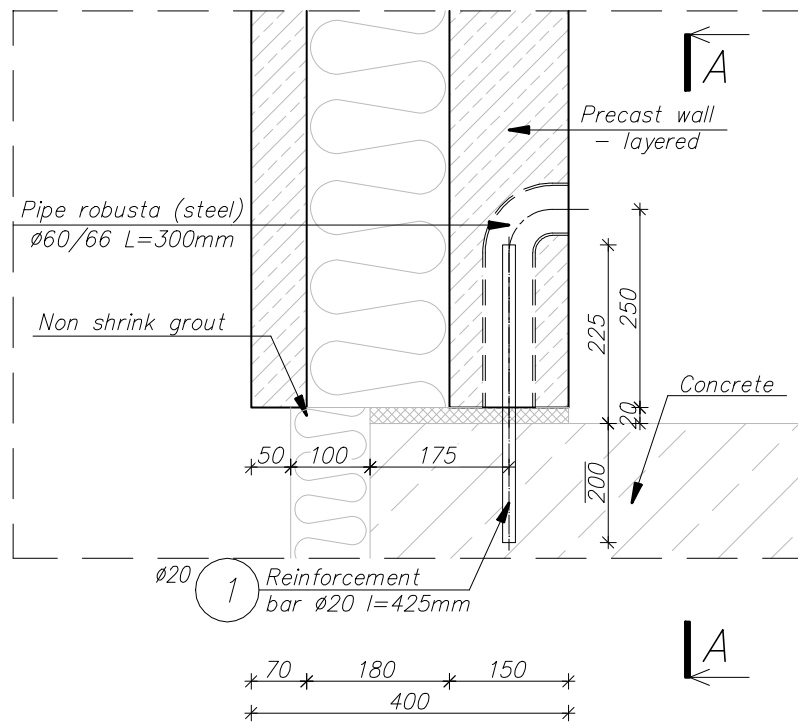

## Section A-A

Przekrój A-A  
skala 1:10

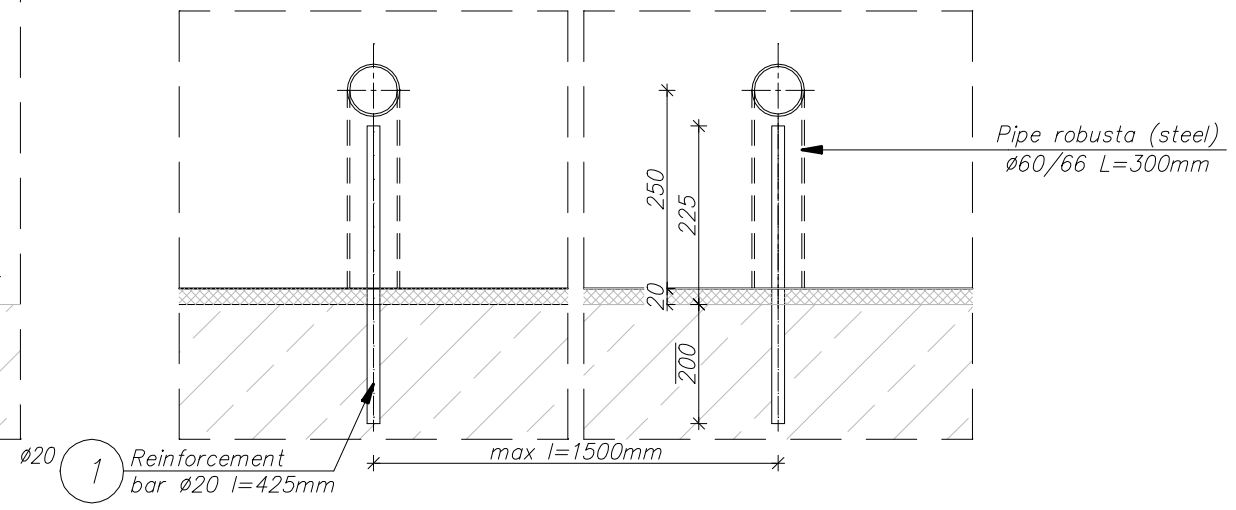

HM FACTORY Sp. z o.o.

# Detail of wall connections – type 4

Detal łączenia ścian – typ 4  
skala 1:10

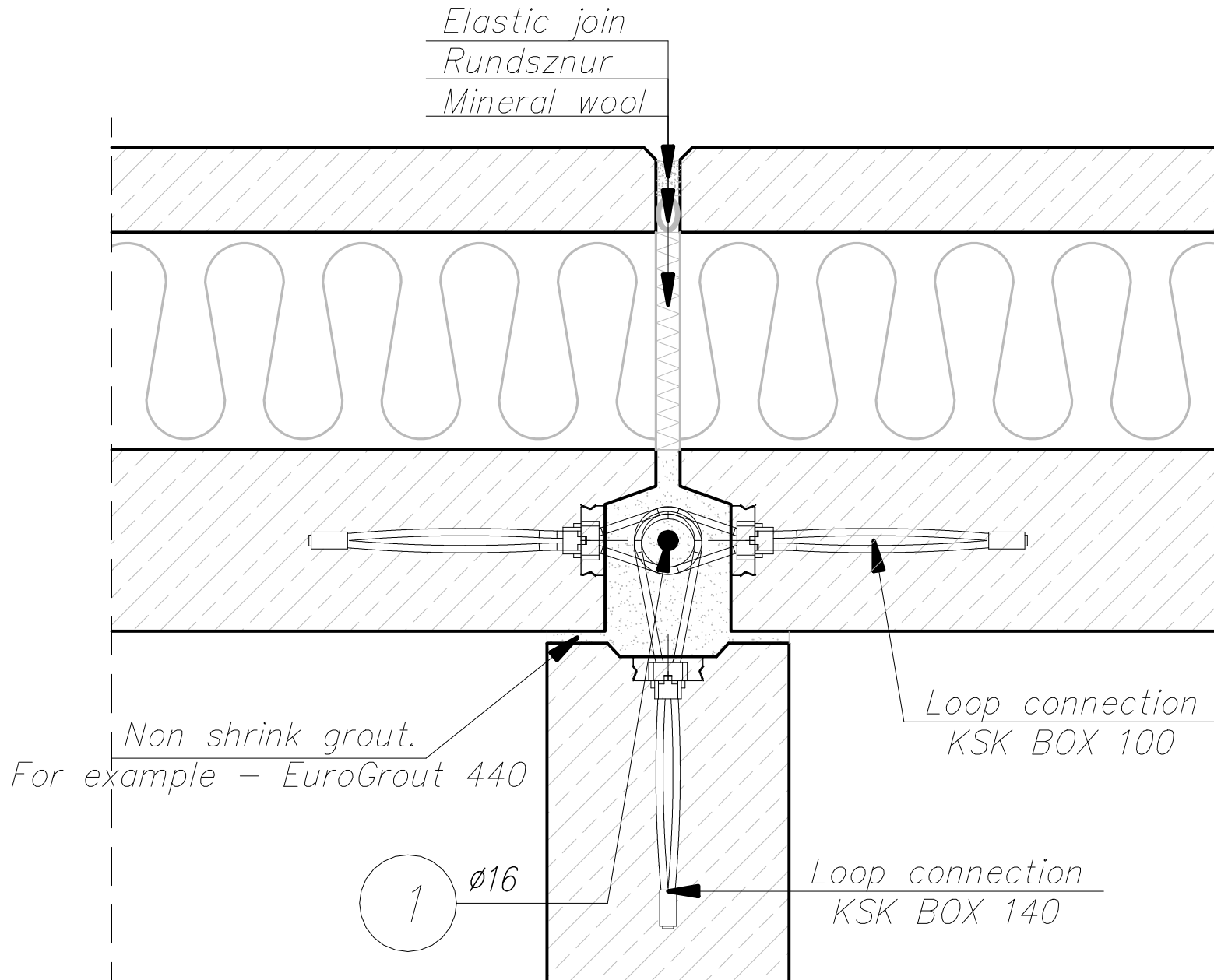

HM FACTORY Sp. z o.o.